

# FUSION UV SYSTEMS, INC.

## Model F300S and F300SQ



The F300S is a combination of the best features of the production-proven 300 watt/inch microwave powered electrodeless lamp, packaged in a more compact form. This economical, remotely controlled lamp now enables you to realize the full benefit of Fusion UV in your production process.

- Popular "H", "D" and "V" bulb spectra available. The microwave lamp operates without the metal electrodes required in arc lamps and provides the most reliable, stable, and efficient UV curing system. It is the curing system of choice where minimal down time, minimum maintenance, and maximum product output are key performance parameters.

### F300S: Modular Adaptability

The compact design of the F300S allows easy installation in terms of space and orientation. The irradiator module can be equipped with its own integral blower or, for even more compact requirements, an adaptor allows cooling provided by a remotely located blower. The power supply can be placed at any convenient location and connected to the irradiator module by easy-to-install cables.

### F300S: Plug-In Simplicity

Connections are all pre-wired for easy plug-in installation. Power supplies can be interconnected to operate as a single system.

### F300S: Building Block Versatility

Used as a single unit, the F300S provides a complete, self-contained six-inch curing source. Its modular design allows two or more irradiator modules to be placed end-to-end for curing wider processes. Power supplies can be stacked on one another and interconnected into a single control system.

### F300SQ: Quick Restart Option

An optional power supply feature permits the bulb to be restarted at any time after it has been turned off (eliminating the short wait time normally required to allow the bulb to cool).

### The Electrodeless Bulb

- Several different spectral outputs. Enables users to optimize UV wavelength with the reactive sensitivity of chemistry being used and the desired properties of the end product.
- Long bulb life. This six-inch electrodeless bulb (BF9H) is warranted for 8,000 hours, independent of on/off cycles.

- Rapid start and restart. Eliminates requirement for shutters and associated shutter mechanisms.
- High UV/Low IR output. Optimized bulb fill to give maximum ultraviolet output with minimum infrared. Less heat to substrate.
- Rapid bulb change. Bulb replacement can be accomplished in minutes.
- Full cure width maintained throughout bulb life. No blackening at bulb ends; therefore, no decrease in cure width.

### The Irradiator

- Electrodeless technology. Frequent on/off operations have no adverse effect on UV output or bulb lifetime. Bulb also maintains spectral consistency throughout its life.
- Focused elliptical reflector. Concentrates maximum UV energy on substrate.
- Positive air cooling. Positive air flow through the reflector. Air may be supplied by integral blower or by remote blower.
- Engineered modular design. Modules can be placed end-to-end for uniform cure, and controlled individually or together.

### The Power Supply

The power supply incorporates state-of-the-art technology. The benefits are:

- On/off/standby control. Allows easier, quicker start-up procedures.
- Safety interlocks.
- Production line connections. Lamps automatically switch on and off with production line.
- Production interlock. Lamp output monitored to eliminate product scrap or loss.
- Pullout control board. Eases service and component change.
- Full fault indicator array. If any section of the UV curing system fails, controls indicate the location of the failure.
- Master/slave option. For multiple power supply configuration. User programs master power supply to control others.
- Interconnectability. Can be intermixed with and controlled by other Fusion UV power supplies with appropriate interconnect cable.

# Model F300S and F300SQ: Standard six-inch lamp system

## SPECIFICATIONS

Specifications are for a single lamp system consisting of irradiator and power supply. Larger systems are constructed by placing lamp modules end-to-end; power supplies may be stacked and interconnected. F300S system uses P300MT power supply, F300SQ system uses P300MQ power supply.

### Irradiator: Models I300MB, I300M, I301M

Available with integral blower (I300MB), or with 3 inch diameter hose adaptor for remote blower (I300M or I301M).

**Lamp Power:** 300 w/in (120 w/cm); 1800 watts total.

**Bulb Type:** Standard style BF9. Standard spectra available.

**Dimensions:** 6.7" (168 mm) long (along bulb axis), x 8.2" (208 mm) wide at lamp face.

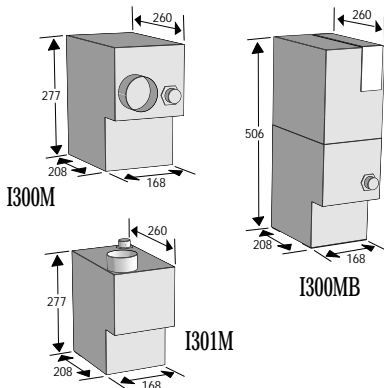

#### Height:

- I300MB 19.9" (506 mm). Blower top 6.7" (168 mm) x 10.3" (260 mm).
- I300M/I301M 10.9" (277 mm). Top surface 6.7" (168 mm) x 10.3" (260 mm).

#### Weight:

- I300MB 30 lbs. (14 kg).
- I300M/I301M 17 lbs. (8 kg).

**Cooling:** Minimum 100 cfm (2.8 m<sup>3</sup>/min) of filtered air at 2.6" water gauge (650 Pa) at the inlet [1.8" (450 Pa) measured at the housing], supplied by modular blower or via 3" diameter flexible hose from remote blower (not included).

**Reflector Geometry:** Semi-elliptical, focuses at 2.1" (53 mm) from irradiator face.

**Fasteners:** Metric.

**Substrate Location:** 2.1" (53 mm) from irradiator face, for maximum irradiance.

**Mounting Position:** Can be mounted and operated in any position.

**Mounting Enclosure:** Supplied as custom item (must have exhaust system with approximately 130 cfm capacity per irradiator).

### Power Supply: Model P300MT

**Dimensions:** 13.9" (353 mm) wide x 7" (180 mm) high x 15.8" (400 mm) deep. An additional 12" (300 mm) clearance is recommended for cable connection access at rear.

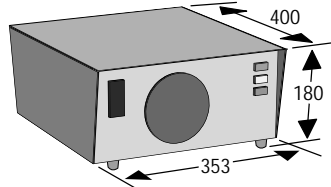

**Weight:** 68 lbs. (31 kg).

**Cooling:** Self contained internal fan.

**Control Functions:** Power ON/OFF; Lamp: ON/STANDBY/OFF-RESET.

#### Interlocks:

- UNIT: Lamp Out, Power Imbalance, Power Error, Power Interrupted, Power Supply Temperature, Blower Pressure.
- SYSTEM: System Blower, External Interlock, RF Interlock (RF Detector).

**Test Points:** Available on front panel.

**RF Detector:** Model RF1, with 13' (4 m) connecting cable (other cable lengths available).

**Connections:** 13' (4 m) cable assembly from power supply to irradiator (other cable lengths available). Line power connections and fused disconnect to be supplied by user.

**Service Access:** Removal of cover.

**Stacking:** Up to three power supplies may be stacked; soft feet fit into top dimples.

**Power Connection:** 200-240V, 18 amp, 50/60 Hz, 1 phase.

### Power Supply: Model P300MQ

**Quick-Restart Feature:** Maintains low power to bulb during standby (up to 40 seconds) to permit lamp restart at any time, without 15 second cool-down period.

**Dimensions:** 13.9" (353 mm) wide x 8" (204 mm) high x 23" (584 mm) deep. An additional 12" (300 mm) clearance is recommended for cable connection access at rear.

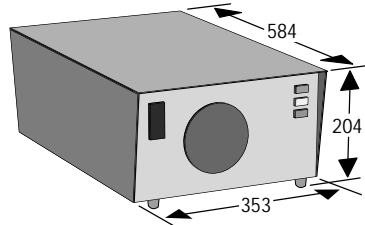

**Weight:** 88.6 lbs. (40.3 kg).

All other specifications same as P300MT.

F300S and F300SQ systems are fully certified to applicable European and USA regulations and requirements.



## FUSION UV SYSTEMS, INC.®

**FUSION UV SYSTEMS, INC.**  
Corporate Headquarters  
910 Clopper Road  
Gaithersburg, Maryland  
20878-1357 USA  
301-527-2660  
FAX: 301-527-2661  
1-888-276-8600 (North American Toll Free)  
www.fusionuv.com  
e-mail: info@fusionuv.com

**FUSION UV SYSTEMS WEST**  
Torrance, California  
310-370-9920  
FAX: 310-370-9152

**FUSION UV SYSTEMS JAPAN KK**  
Tokyo, Japan  
+81-3-5542-3980  
FAX: +81-3-5542-3992

**FUSION UV SYSTEMS**  
Spectris China Ltd.  
Beijing, China  
+86-10-6856-0808  
FAX: +86-10-6802-9962  
Guangzhou, China  
+86-20-8754-7458  
FAX: +86-20-8754-5144

Shanghai, China  
+86-21-5385-5332  
FAX: +86-21-6375-8139

**FUSION UV SYSTEMS**  
Singapore  
+65-6844-5538  
FAX: +65-6844-5539

**FUSION UV SYSTEMS**  
Alton, England  
+44-1-420-544-516  
FAX: +44-1-420-544-138

**FUSION UV SYSTEMS GMBH**  
Martinsried, Germany  
+49-89-899 631-0  
FAX: +49-89-899 631-10

**FUSION UV SYSTEMS SARL**  
Maisons-Alfort, France  
+33-1-56-72-16-20  
FAX: +33-1-48-99-76-11

Corporate Headquarters Certification

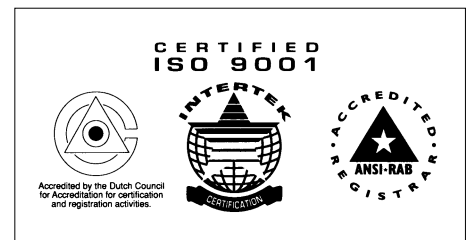

U.S. Patent No. 3911318; 3872349;  
3983039; 4042850; 4208587; 4359668;  
4313969; 4269581; 4485332; 4507587  
U.K. Patent No. 1482950  
Japan Patent No. 1142145; 1130584  
France Patent No. 7428765  
Canada Patent No. 1024246  
Other U.S. and Foreign Patents Pending.

We reserve the right to incorporate changes and improvements without notice.

6/03 Printed in USA SB 623  
©2003 Fusion UV Systems, Inc.  
The logo symbol and Fusion UV Systems, Inc. are registered trademarks of Fusion UV Systems, Inc.

